

Schematic diagram, Part 1

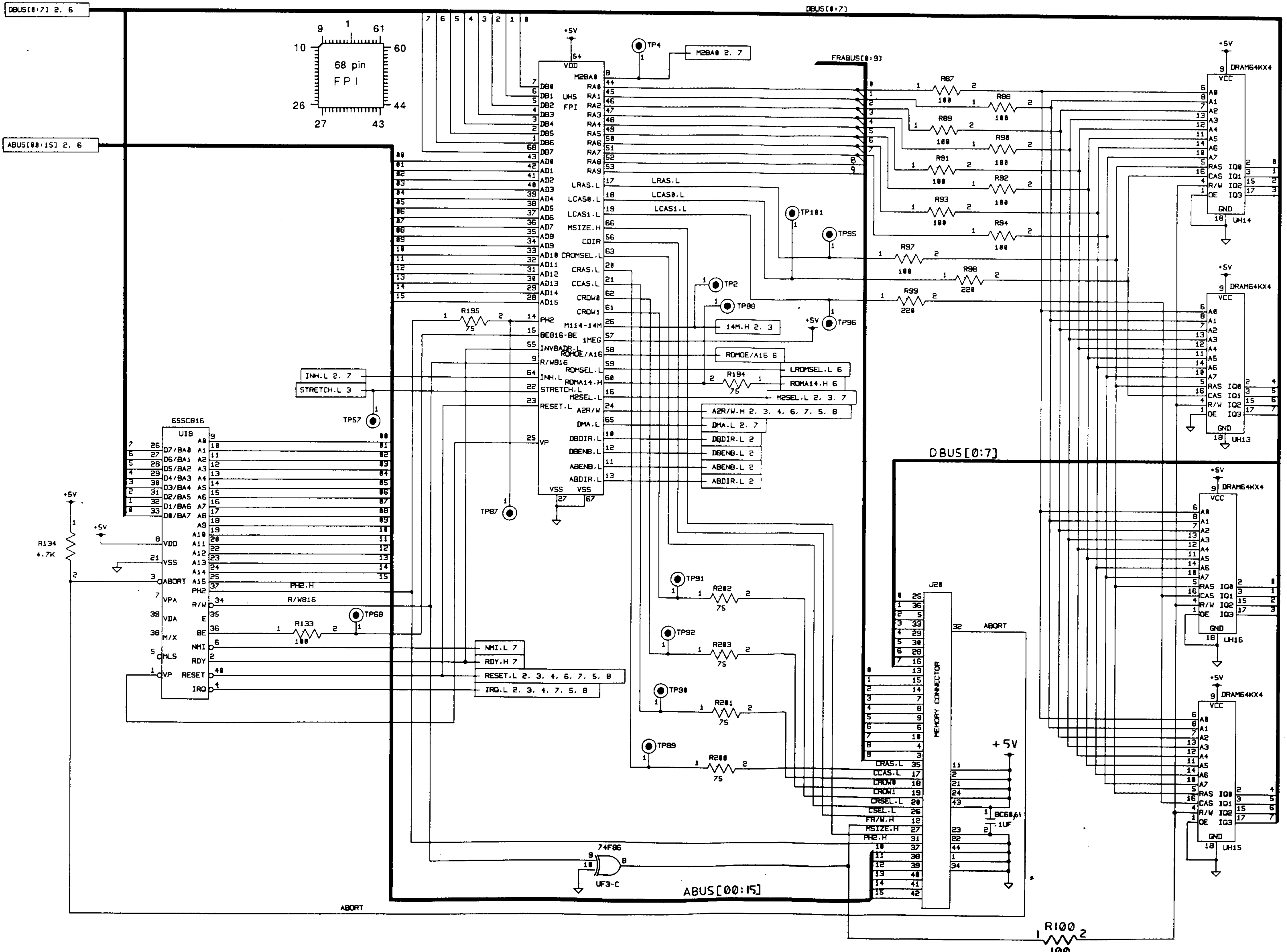

Schematic diagram, Part 2

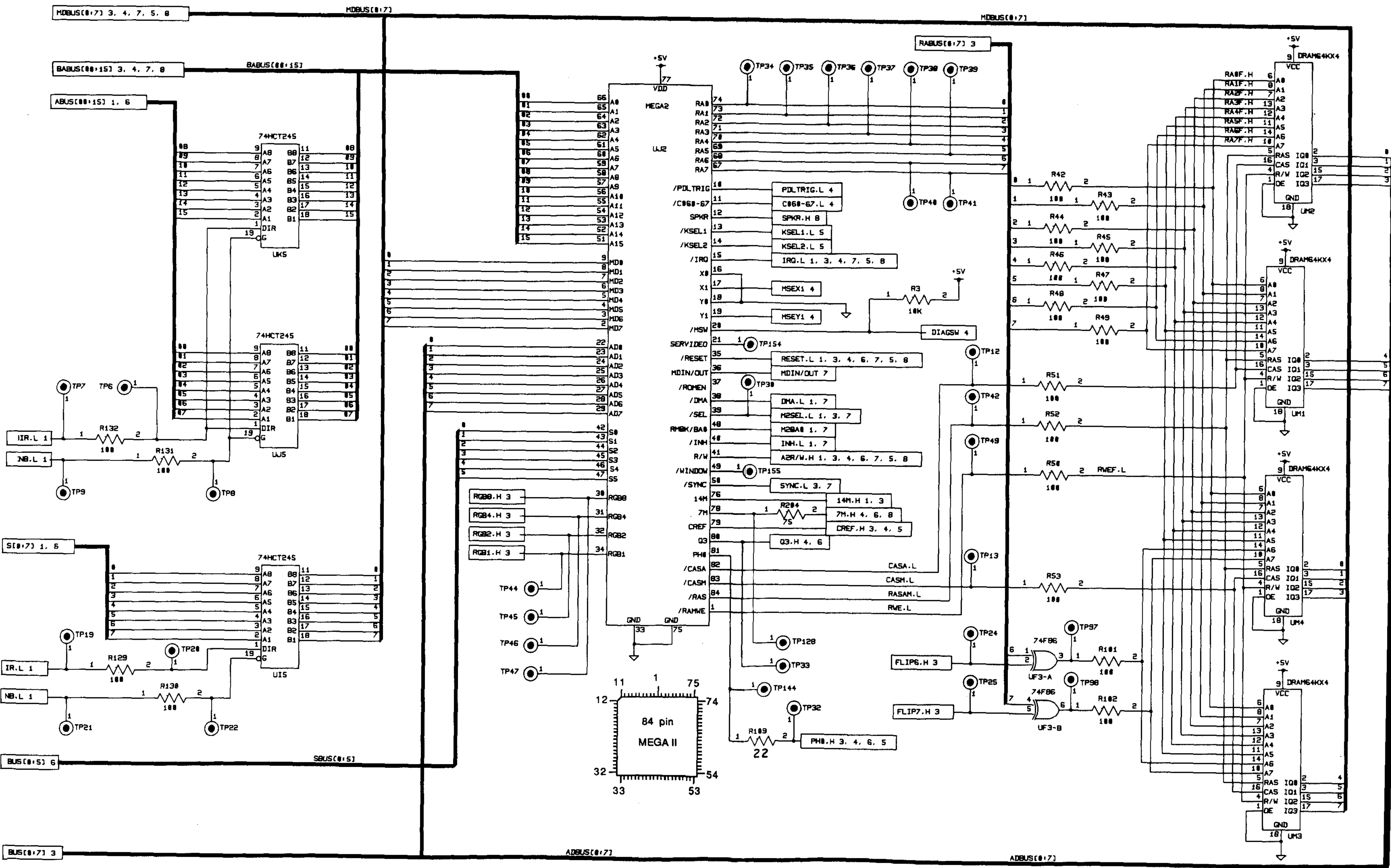

Schematic diagram, Part 3

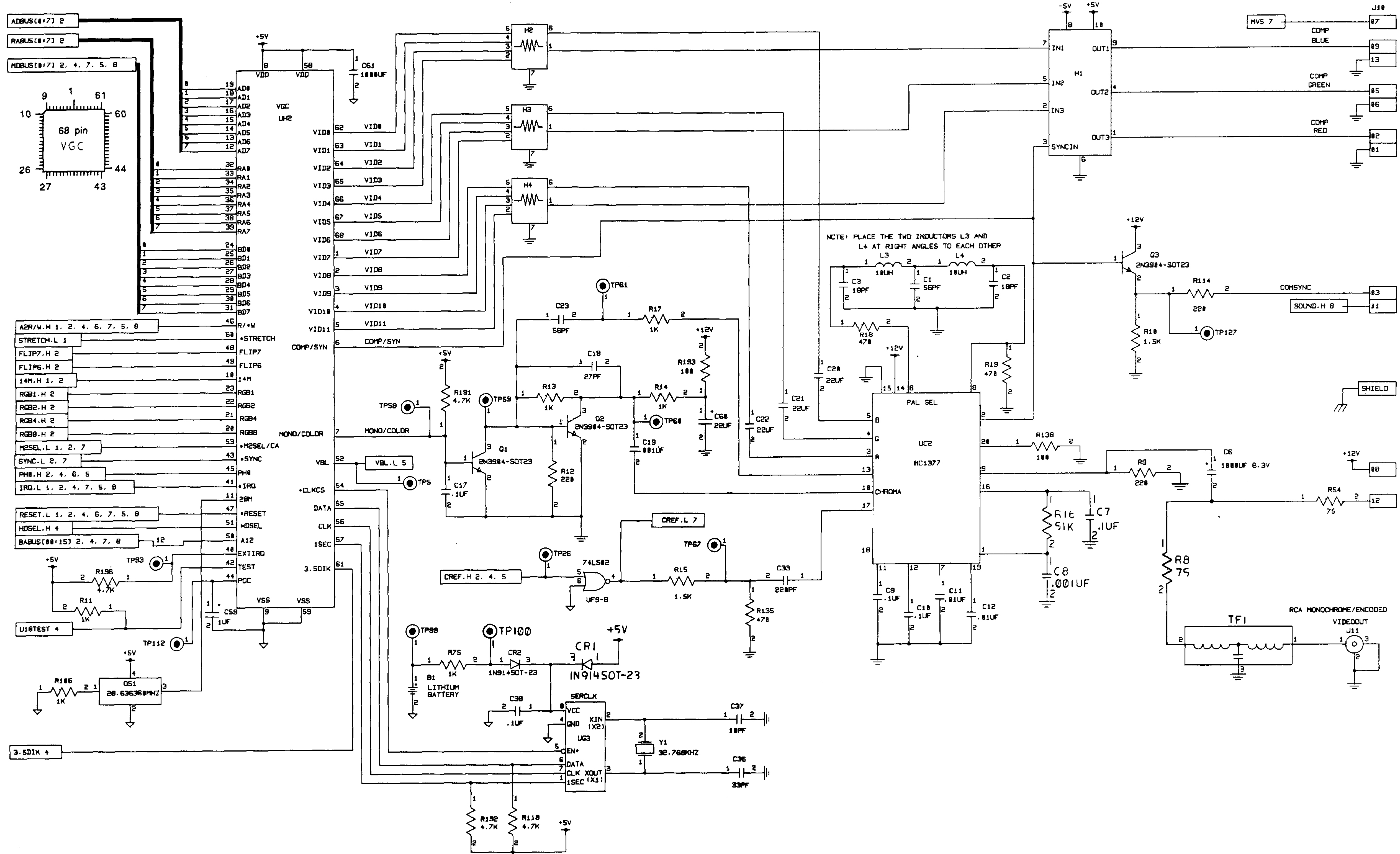

Schematic diagram, Part 5

MOBUS (0, 1, 2, 3, 4, 7, 8)

MOBUS (0, 7)

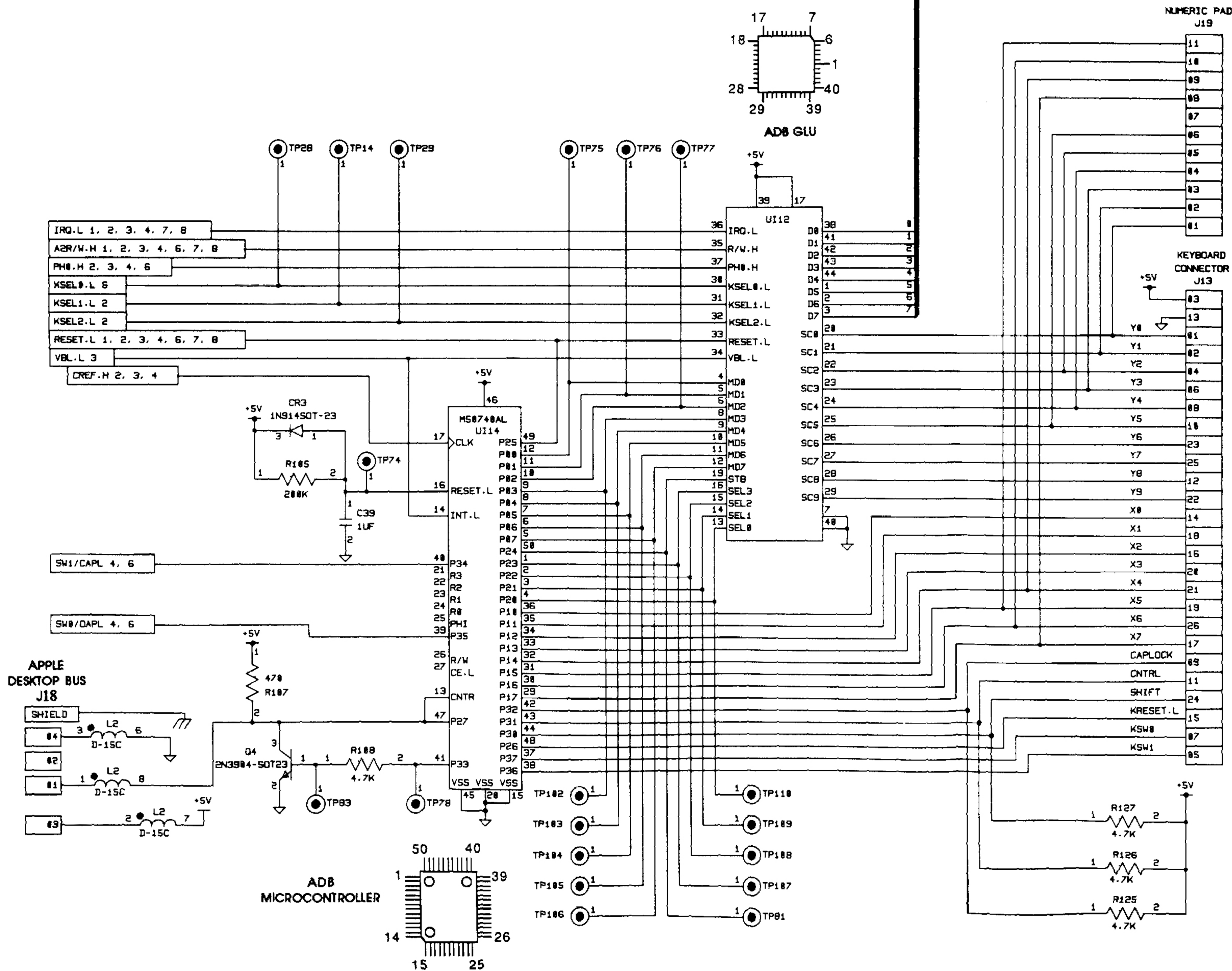

Schematic diagram, Part 6

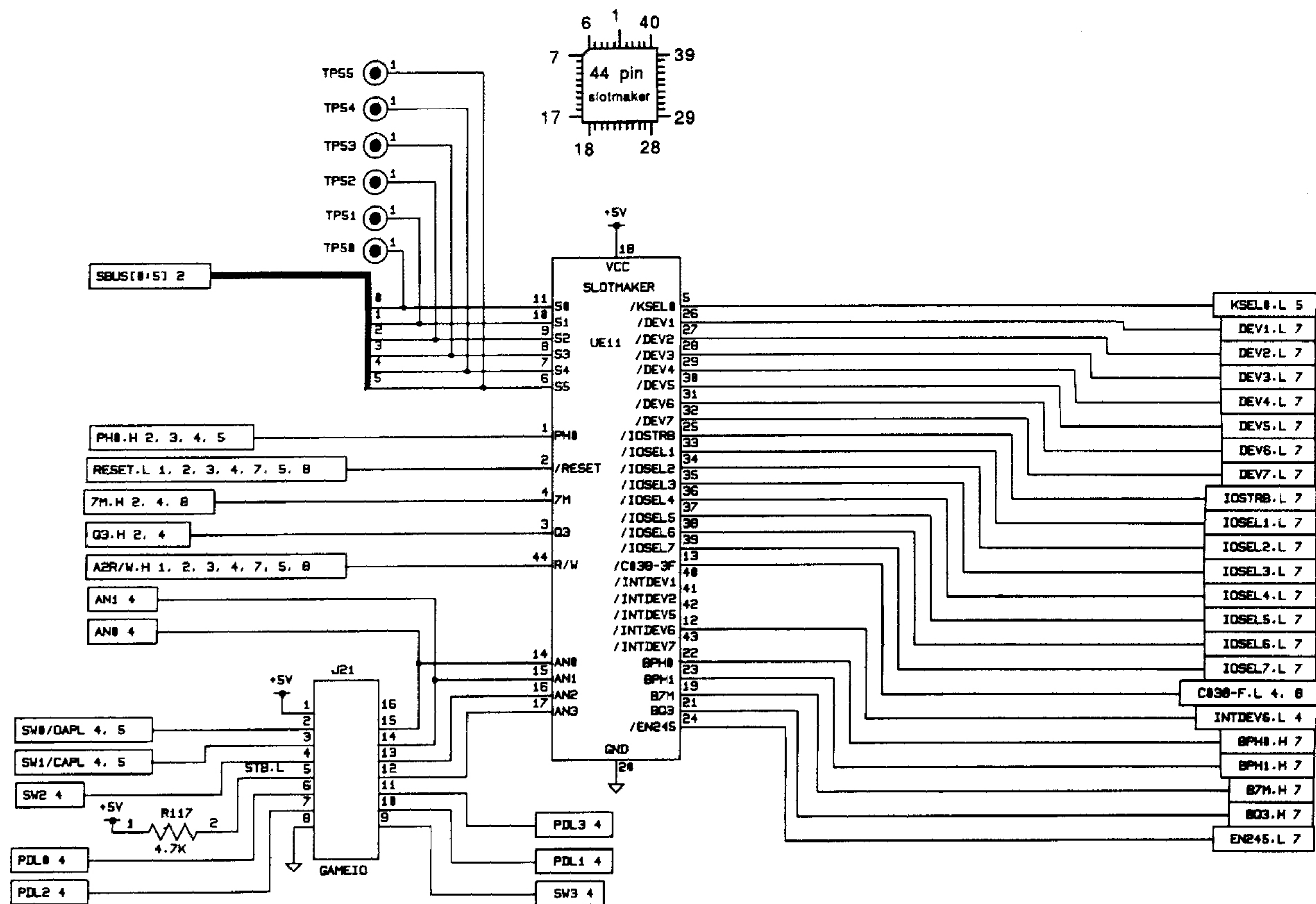
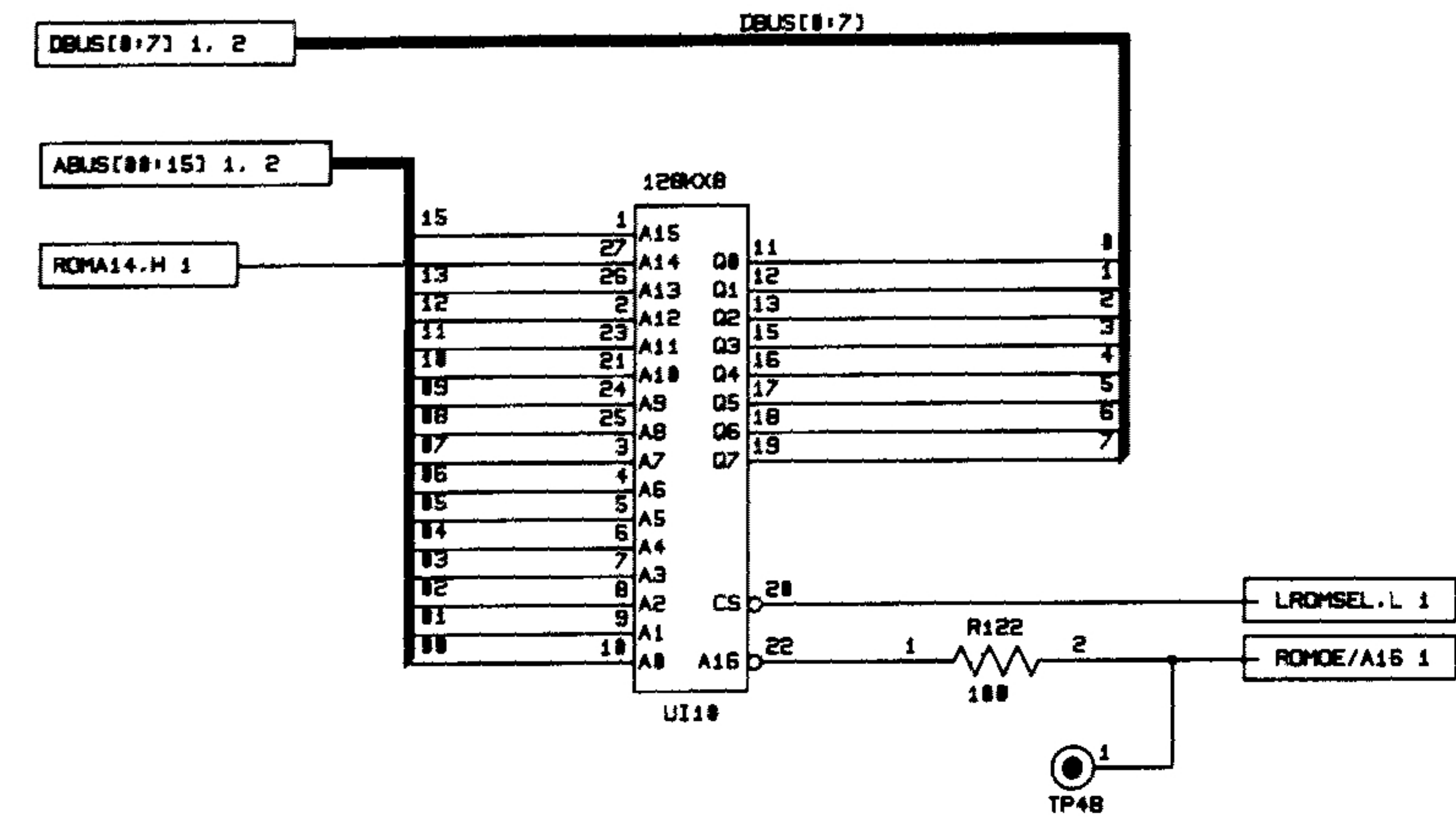

BYPASS CAPACITORS

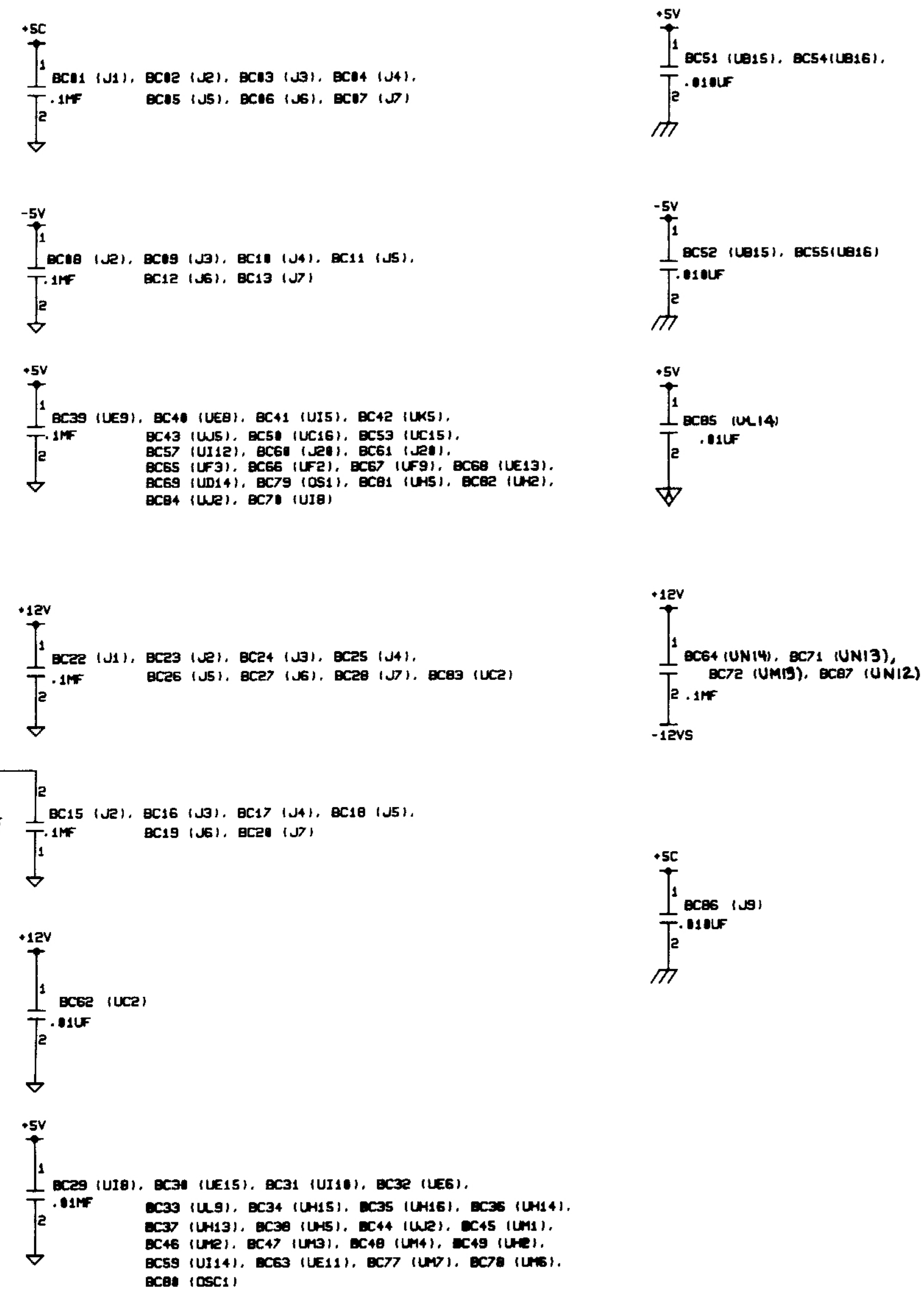

Schematic diagram, Part 7

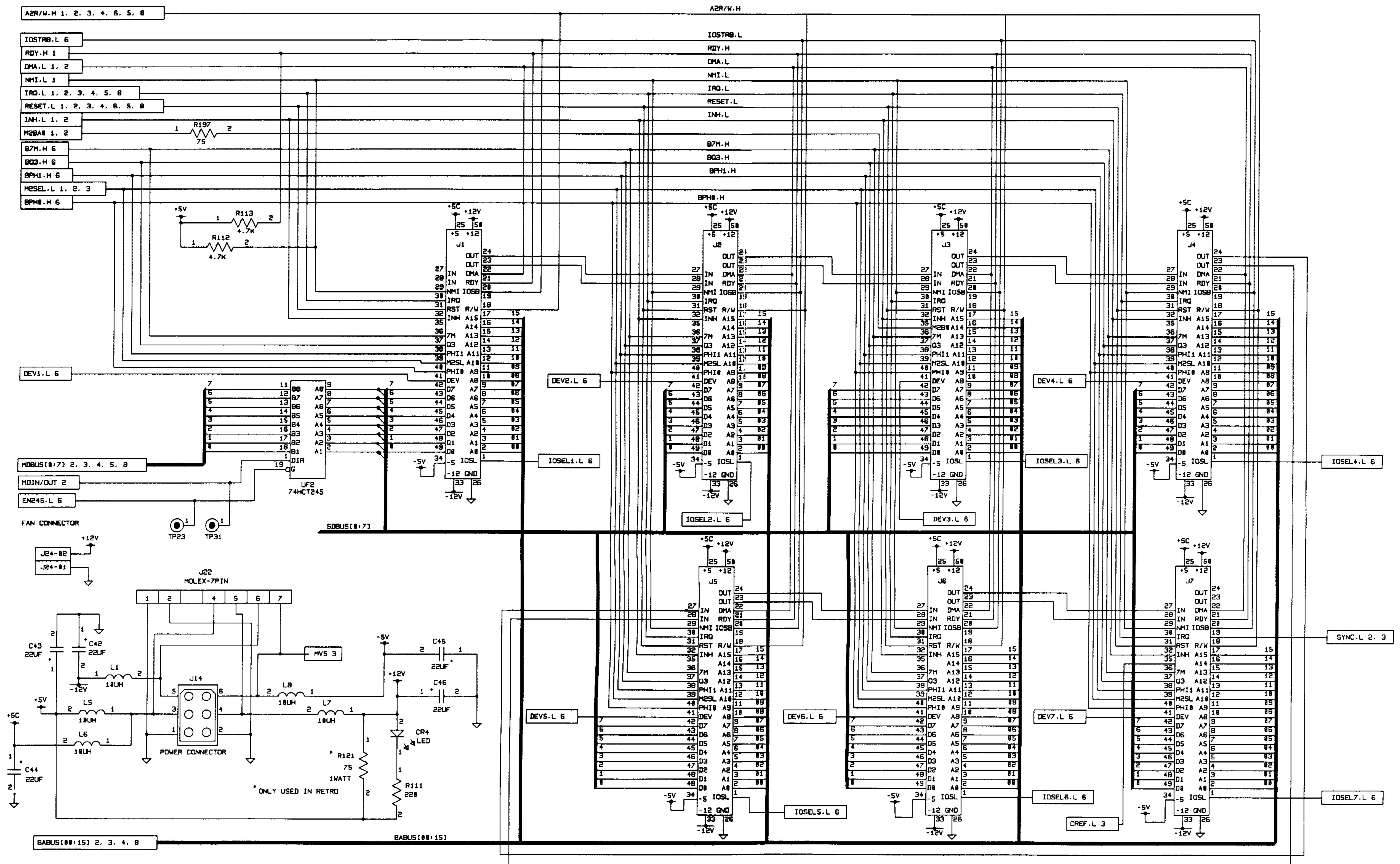

Schematic diagram, Part 8

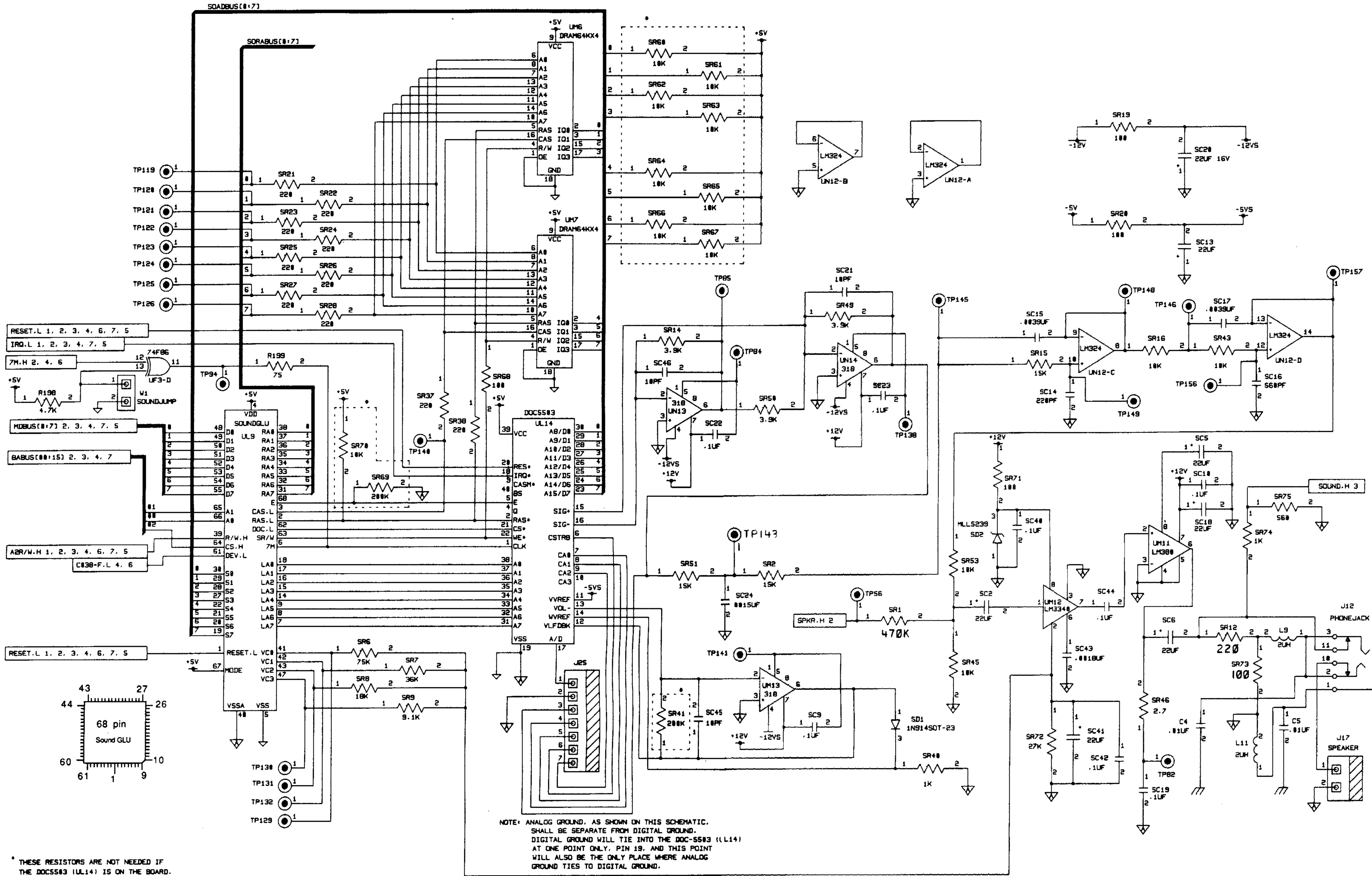

* THESE RESISTORS ARE NOT NEEDED IF THE DOC5503 (UL14) IS ON THE BOARD.